

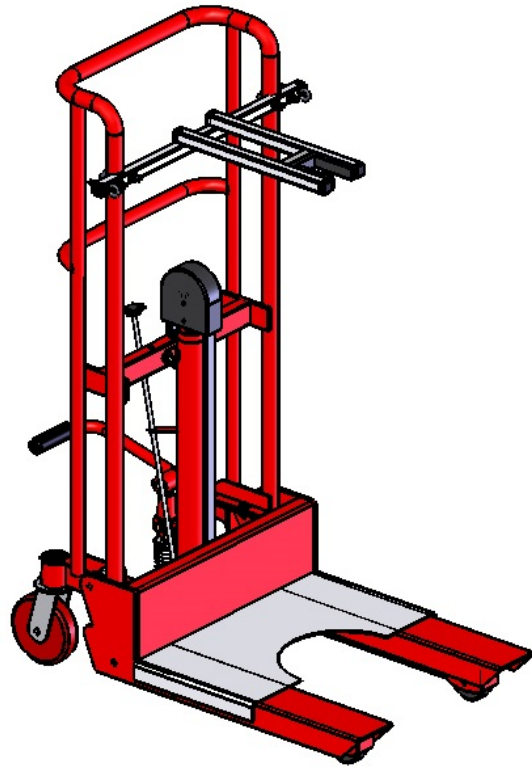

AQUATRAM[®] 360

ACCESS LIFT TRANSPORT CART



INSTALLATION AND USER'S GUIDE

IMPORTANT SAFETY INSTRUCTIONS
READ AND FOLLOW ALL INSTRUCTIONS
SAVE THESE INSTRUCTIONS

OPERATING INSTRUCTIONS:

- 1. WARNING- TO REDUCE RISK OF INJURY, DO NOT PERMIT CHILDREN TO USE THIS PRODUCT.**
- 2. WARNING- DO NOT PERMIT CHILDREN TO PLAY ON THIS PRODUCT.**

NOTE: BEFORE USING THE CART FOR THE FIRST TIME READ THIS SECTION COMPLETELY AND FAMILIARIZE YOURSELF WITH THE FEATURES OF THE TRANSPORT CART.

STEP 1: Before using the transport cart first remove the 1/2" bolt in the fixing anchor using a 3/4" wrench. Also, the AquaTRAM® 360 Pool Lift should be all the way up. The cart should be lined up from behind the lift so that the fork can engage with the mast (see diagram). Also the cart should be fully lowered. To lower the cart, turn the control knob counterclockwise. Then turn the knob back clockwise to be ready to lift.

STEP 2: Line the cart up centered on the mast and slide the cart forks under the lift until the fork captures the mast. Continue sliding until the fork is fully engaged and the cart stops.

STEP 3: Locate the strap and attach it to the eye-bolts (either side of the fork assembly) with the s-hooks. Tighten the strap around the mast to keep the lift from falling over during lifting and transport. Make the strap just snug to start with so that the post of the lift doesn't bind in the anchor. Adjustment may be required to allow the post to slide out of the anchor.

STEP 4: Pump the foot pedal to raise the lift out of the anchor. If nothing happens make sure the control knob is turned clockwise. If the post binds in the anchor gently shake the handle to free it up. If this doesn't work try tightening or loosening the strap. Raise the lift only enough to clear the deck/anchor by an inch or two, Don't let the fork hit the battery. The lift is ready for transport

IF THE LIFT IS STUCK (WON'T MOVE) DON'T PUMP THE FOOT PEDAL. THIS MAY CAUSE DAMAGE TO THE LIFT OR THE CART. MISUSE OF THE CART MAY VOID YOUR WARRANTY.

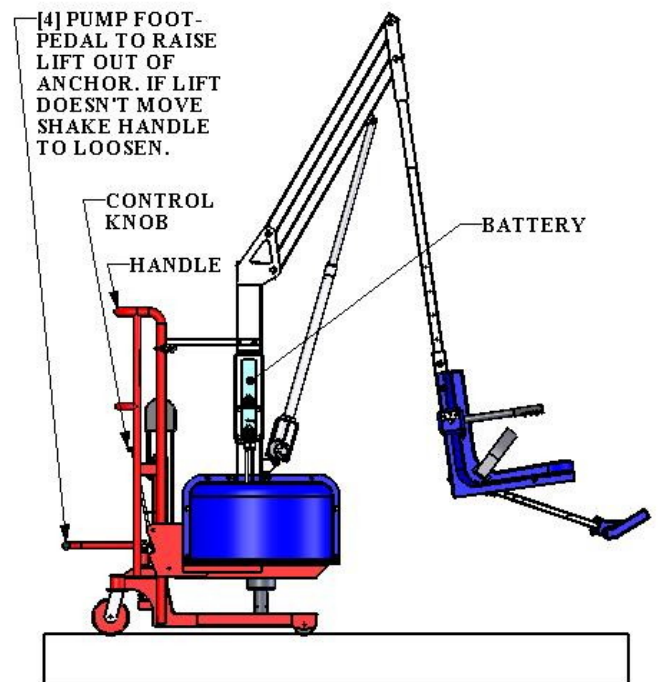
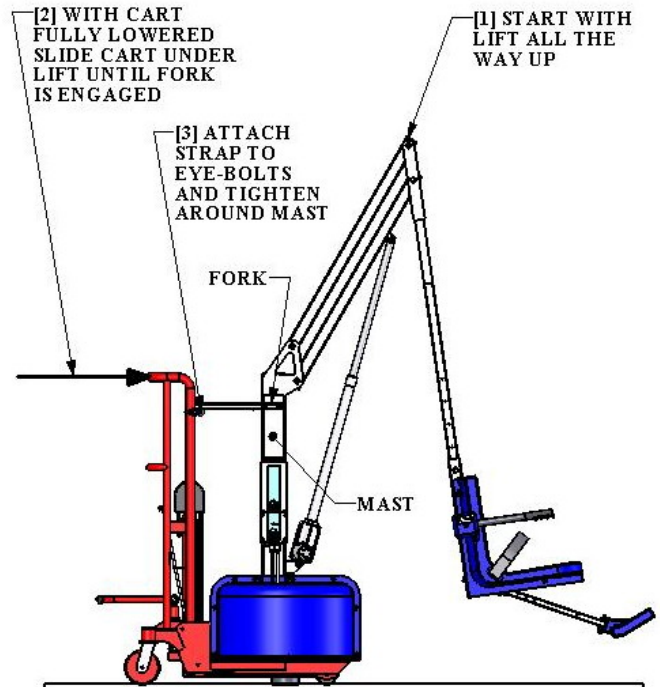

NOTE: RAISE THE LIFT ONLY ENOUGH TO CLEAR THE DECK. DON'T LET THE FORK COME INTO CONTACT WITH THE BATTERY/BRACKET.

IF LIFT DOESN'T COME OUT OF THE ANCHOR EASILY LOOSEN THE STRAP AND TRY AGAIN.

THE CONTROL KNOB WORKS AS FOLLOWS:
TO LIFT - TURN FULLY CLOCKWISE
TO LOWER - TURN COUNTERCLOCKWISE



AquaTRAM® Pool and Spa Lift Transports ONE (1) YEAR PRODUCT WARRANTY

Pentair Water Pool and Spa, Inc. ("Pentair") warrants to the original end user purchaser that products manufactured by Pentair, when properly installed in accordance with assembly and installation instructions and properly used and maintained, shall be free from defects in material and workmanship for a period of **one (1) year from the date of original purchase**, provided that Pentair receives prompt notice in writing of any defect or failure and satisfactory proof thereof, with the following exceptions:

Exceptions:

- This warranty specifically excludes reimbursement for labor to remove, repair, or install the product and any freight charges.
- This warranty does not cover any damages due to accident, misuse, abuse, negligence or failure to properly maintain any products, or normal wear and tear from day to day operations.
- In the event that any products are altered, repaired, or improperly installed by anyone without the prior written approval by Pentair, all warranties are void.

To initiate a warranty claim, the owner of a Pentair product must provide the place of purchase, in writing, with a full description of the product, its serial number, the dates of purchase and installation, and the exact nature of the defect. Within thirty (30) days after receipt of a written warranty claim by Pentair, and barring any unforeseen delays, the place of purchase will be notified of Pentair's decision regarding the claim. All warranty calculations are from date of original purchase at manufacturer's suggested retail price.

If requested by Pentair, any defective product must be returned, freight prepaid, to Pentair's designated factory location or duly appointed distributor for inspection and/or repair. Pentair will, at its option, repair or replace the failed or defective item, and deliver the repaired product or replacement to the seller of the product, freight prepaid to the destination provided for in the original order. Products returned to Pentair for which Pentair provides replacement under this limited warranty shall become the property of Pentair.

A new warranty period shall NOT be established for the repaired or replaced products. Such products shall remain under warranty only for the remainder of the original warranty period on the original products purchased.

This written limited warranty constitutes the final, complete and exclusive statement of warranty terms. No person or organization is authorized to make any other specific or implied warranties or representations on behalf of Pentair.

THE WARRANTIES SET FORTH HEREIN ARE IN LIEU OF ALL OTHER WARRANTIES, EXPRESSED OR IMPLIED, WHICH ARE HEREBY DISCLAIMED AND EXCLUDED, INCLUDING WITHOUT LIMITATION ANY WARRANTY OF MERCHANTABILITY OR FITNESS FOR A PARTICULAR PURPOSE OR USE.

THE SOLE AND EXCLUSIVE REMEDIES FOR BREACH OF ANY AND ALL WARRANTIES WITH RESPECT TO THE PRODUCTS SHALL BE LIMITED TO REPAIR OR REPLACEMENT AT PENTAIR'S DESIGNATED FACTORY LOCATION, OR DULY APPOINTED DISTRIBUTOR, OR IN PLACE AT PENTAIR'S OPTION. IN NO EVENT SHALL PENTAIR'S LIABILITY EXCEED THE ENTIRE AMOUNT PAID TO PENTAIR BY THE ORIGINAL PURCHASER FOR THE FAILED OR DEFECTIVE PRODUCT.

IN NO EVENT SHALL PENTAIR WATER POOL AND SPA, INC. BE LIABLE FOR ANY INCIDENTAL, CONSEQUENTIAL, SPECIAL, INDIRECT, PUNITIVE OR EXEMPLARY DAMAGES OR LOST PROFITS FROM ANY BREACH OF THIS LIMITED WARRANTY OR OTHERWISE.

Pentair Commercial Aquatics™, A Division of Pentair Water Pool and Spa, Inc.
1620 Hawkins Ave., Sanford, NC 27330
1351 Route 55, LaGrangeville, NY 12540



1620 HAWKINS AVE., SANFORD, NC 27330 • (919) 566-8000
10951 WEST LOS ANGELESE AVE., MOORPARK, CA 93021 • (805) 553-5000

All Pentair trademarks and logos are owned by Pentair or one of its global affiliates. Pentair Commercial Aquatics™ and AquaTRAM® are trademarks and/or registered trademarks of Pentair Water Pool and Spa, Inc. and/or its affiliated companies in the United States and/or other countries. Unless expressly noted, names and brands of third parties that may be used in this document are not used to indicate an affiliation or endorsement between the owners of these names and brands and Pentair Water Pool and Spa, Inc. Those names and brands may be the trademarks or registered trademarks of those third parties. Because we are continuously improving our products and services, Pentair reserves the right to change specifications without prior notice. Pentair is an equal opportunity employer.

© 2014 Pentair Water Pool and Spa, Inc. All rights reserved.



P/N 11268 REV B 9/18/14